

DEGON DG166-5.0-03P-14-00A(H) alternative
 3W P5MM TERMINAL BLOCK - GREEN - LEAF SPRING

REV	CONTENT	CHK	DATE
V0.0	CONTENT	MYZ	21.06.28

Electrical :

- | | | |
|---|----------------|------------------------|
| | UL | IEC |
| 1. Rated Voltage : | 300V | 250V |
| 2. Rated Current : | 15A | 22A |
| 3. Torque Value : | M3 , 4.43Lb.in | M3 , 0.5N.m |
| 4. Wire Range: | 22-12AWG | 1.0-2.5mm ² |
| 5. Stripping Length : | 6-7mm | |
| 6. Withstanding Voltage : | AC2000V/1Min. | |
| 7. Operating Temperature : | -40°C~+105°C | |
| 8. RoHS Compliance | | |
| 9. Safty Approval : | ULus CE | |
| 10. "★" is the key quality control point. | | |

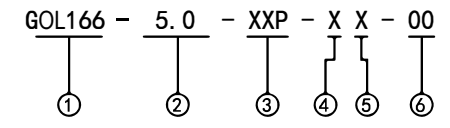
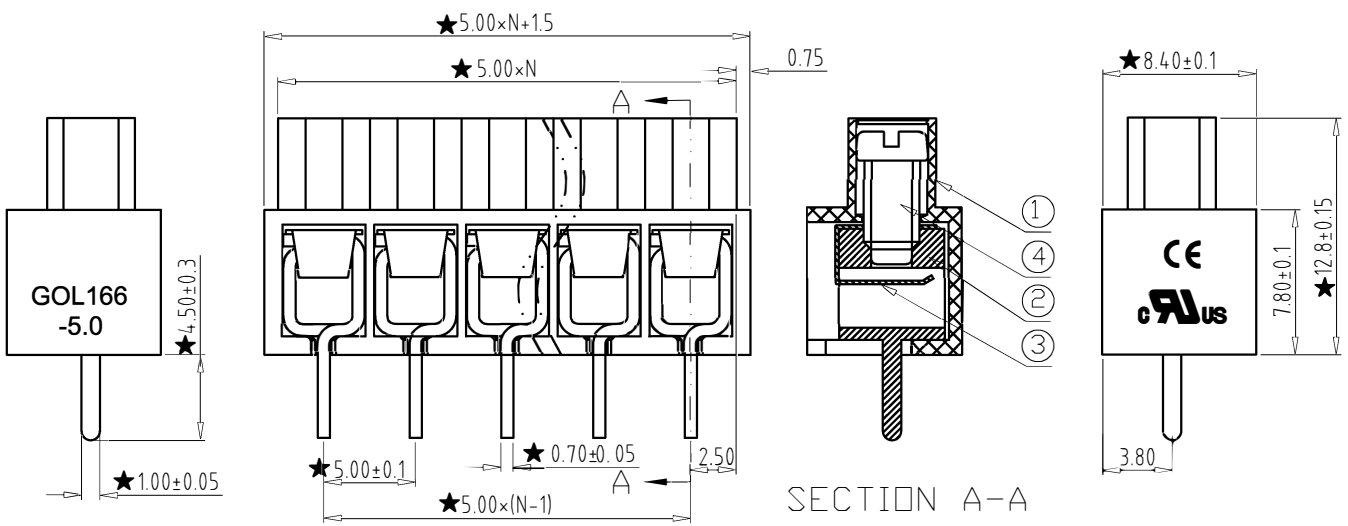
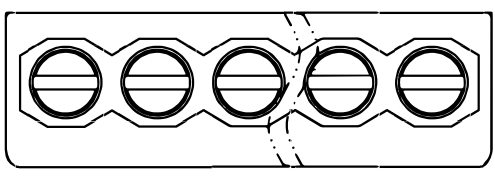

- ① Series No. ④ 1 Single Pitch
 2 Double Pitch
- ② Pitch ⑤ Color: 1 Grey
 2 Blue
 3 Black
 4 Green
 5 Orange
 6 Red
 7 Transparent
 8 Yellow
 9 White
- ③ Poles
02 02Contacts
03 03Contacts
...
24 24Contacts
- ⑥ Customer Request : 00--Standard

Total Pitch Tolerances in mm								Nominal dimension range in mm																⊥	≡	-	//
over 0	over 30	over 53	over 70	over 90	over 115	over 150	over 250	over 30	over 30	over 53	over 70	over 90	over 115	over 150	over 200	over 250	over 30	over 10	over 0	over 100	over 150	all	0	100	150		
±0.18	±0.20	±0.25	±0.3	±0.35	±0.44	±0.60	±0.70	±0.20	±0.25	±0.30	±0.35	±0.44	±0.55	±0.70	±0.80	±0.90	0.2	0.3	0.3	0.2	0.3	0.5					



4	SCREW	XX	N	STEEL	Zn Plated
3	SHRAPNEL	XX	N	STAINLESS STEEL	--
2	PIN HEADER	XX	N	BRASS	Tin Plated
1	HOUSING	XX	1	PA66 UL94V-0	SEE NOTE
ITEM	NAME OF PART	NO. OF PART	Q'TY	MATERIAL	NOTE
DWG.	MYZ	DATE	21.06.28	SIZE	A4 UNITS mm SHEET/OF 1/1
CHK.		DATE		SCALE	1:1
APP.		DATE		NAME	GOL166-5.0-XXP-XX-00
	DEGON DG166-5.0-03P-14-00A(H) alternative			DWGNO.	XXXX