

TBP303KV alternative BCE508302KV

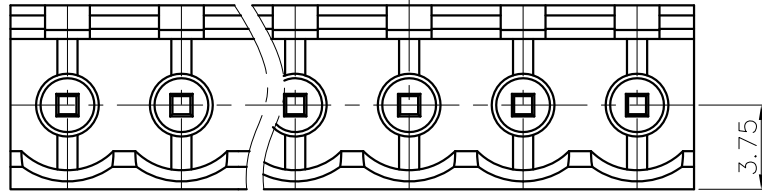

REVISION RECORD				
REV	ECN	DESCRIPTION	DRFT	DATE



NOTES1:

UL Standard

1. Rated voltage/current : 300V / 15A
2. Withstanding voltage : AC1600V/1Min.

IEC Standard

1. Pollution degree	2
Overtoltage category	III
Rate impulse voltage(KV)	4.0KV
Rate voltage(V)	320V
Rate current(A)	20A

NOTES2:

1. Dimension shall be interpreted per ASME Y14.5-2009
2. Pitch : 5.0/5.08mm, Poles : N=02~24P
3. Operating temperature: -40°C~+105°C
4. Undimensioned tolerances:

Pitch range in mm		Nominal dimension range in mm						
To	Over	Over	To	Over	Over	Over	0.1/10	
6	10	24	30	60	100	150	<	
±0.15	±0.20	±0.30	±0.30	±0.50	±0.70	±1.00	±1.30	±2'

5. RoHS Compliance

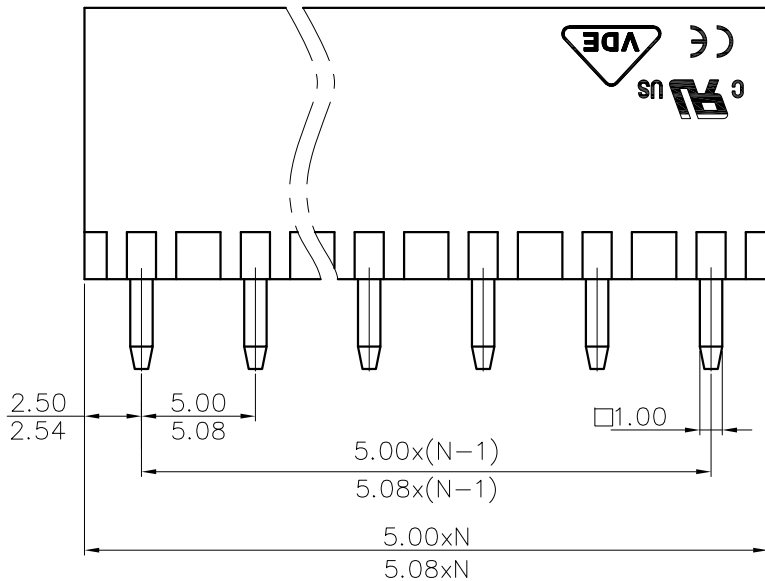
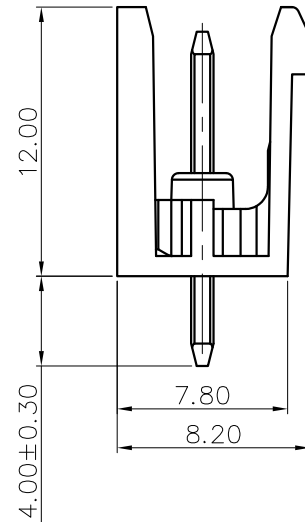

2EDGV - 5.0/5.08 - XXP - 1Y - 00A (H)
 (Series No.) (Pitch) (Poles)(Single Pitch)(Color) : 1. (Grey)
 2. (Blue)
 3. (Black)
 4. (Green)
 5. (Orange)
 6. (Red)
 7. (Transparent)
 8. (Yellow)
 9. (White)
 00A-(Standard)

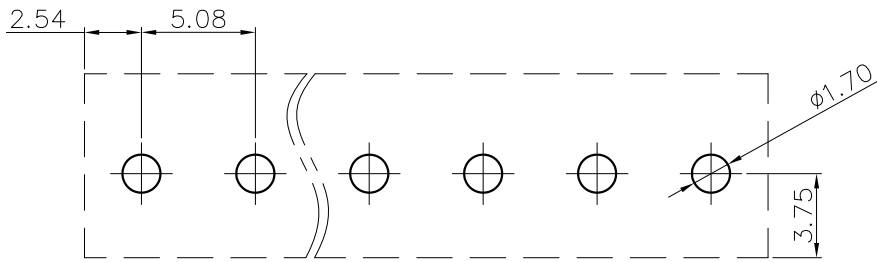

PCB LAYOUT

more info: sales@bec.co.uk

www.bec.co.uk

DETACHED LISTS	PART NO.: /		BEC DISTRIBUTION LIMITED		
	APPD: /	NAME:	TBP303KV alternative BCE508302KV		
	CHKD: /	DRFT:	TITLE: CUSTOMER DRAWING	REV	DO
	DRAWING NO.: /		SHEET	1/1	
	THIRD ANGLE PROJECTION		MM (INCH)	DO NOT SCALE DRAWING	SCALE