

TBP302KVC alternative BCE508302KVC

REVISION RECORD				
REV	ECN	DESCRIPTION	DRFT	DATE

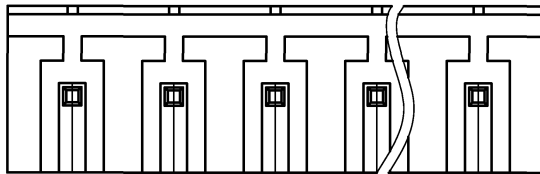

VIEW A

2EDGVC - 5.0/5.08 - XXP - 1Y - 00A (H)

(Series No.) (Pitch) (Poles)(Single Pitch) (Color)

1. (Grey)
2. (Blue)
3. (Black)
4. (Green)
5. (Orange)
6. (Red)
7. (Transparent)
8. (Yellow)
9. (White)

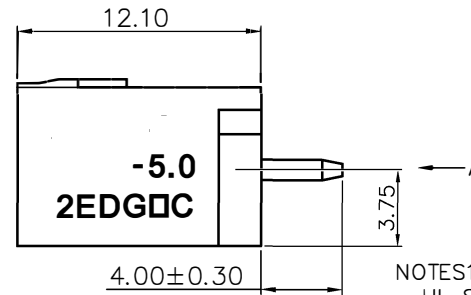
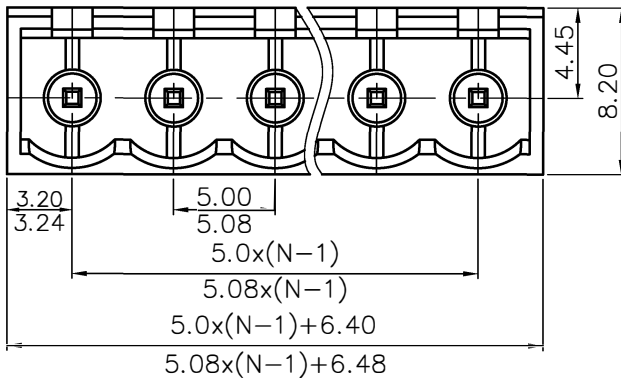
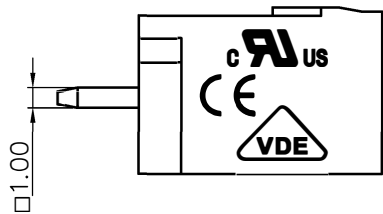

NOTES1:

- UL Standard
- 1. Rated voltage/current : 300V / 15A
- 2. Withstanding voltage : AC1600V/1Min.

IEC Standard

Pollution degree	2
Overtoltage category	III
Rate impulse voltage(KV)	4.0KV
Rate voltage(V)	320V
Rate current(A)	20A

NOTES2:

- 1. Dimension shall be interpreted per ASME Y14.5-2009
- 2. Pitch : 5.0/5.08mm, Poles : N=02~24P
- 3. Operating temperature: -40°C~+105°C
- 4. Undimensioned tolerances:

Pitch range in mm		Nominal dimension range in mm						±0.1/10
To	Over	Over	Over	Over	Over	Over		
6	10	10	30	60	100	150		
6	10	10	30	60	100	150	<	
±0.15	±0.20	±0.30	±0.30	±0.50	±0.70	±1.00	±1.30	
							±2'	

- 5. RoHS Compliance

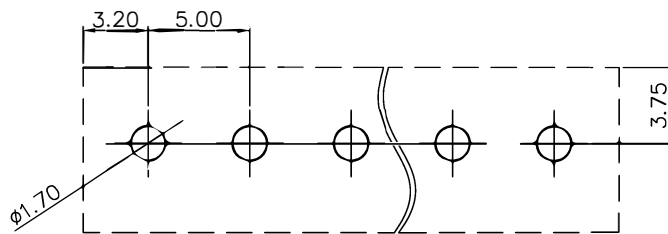

PCB LAYOUT

DETACHED LISTS	PART NO.:	BEC DISTRIBUTION LIMITED		
	APPD:	TBP302KVC alternative BCE508302KVC		
	CHKD:			
	DRFT:	TITLE: CUSTOMER DRAWING	REV	DO
		DRAWING NO.:	SHEET	1/1
	THIRD ANGLE PROJECTION	MM (INCH)	DO NOT SCALE DRAWING	SCALE 1:1

more info: sales@bec.co.uk



www.bec.co.uk