



SS7030 SERIES ~ Spring Air Core Inductors



RoHS Compliant

SHAPE AND DIMENSION

FEATURES

- SMD type air core inductor .
- Tape / Reel packaging available for auto-insertion .
- High Q coils .

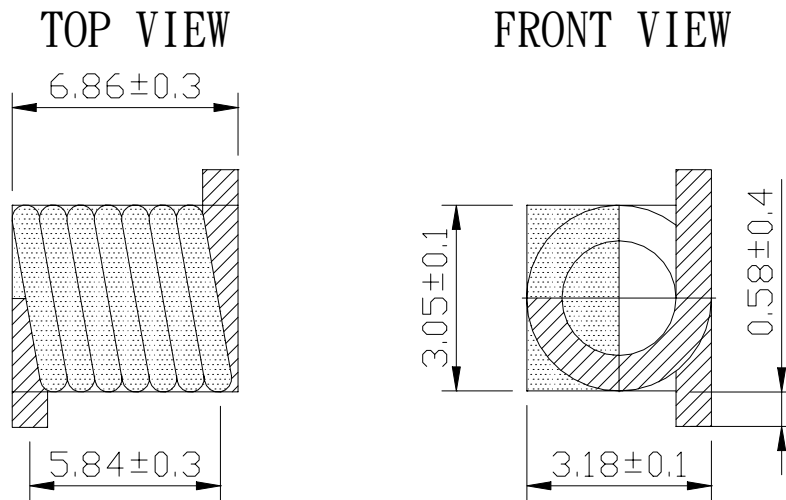

PART NUMBER	INDUCTANCE	Tolerance	Q.	DCR (mΩ)	SRF (GHz)	Irms (A)
	(nH)			(Max)	(Min.)	(Max)
SS7030-17NX-LF	17.5	J , K	100	4.5	2.2	4
SS7030-22NX-LF	22.0	J , K	102	5.2	2.1	4
SS7030-28NX-LF	28.0	J , K	105	6.0	1.8	4
SS7030-35NX-LF	35.5	J , K	112	6.8	1.5	4
SS7030-43NX-LF	43.0	J , K	106	7.9	1.2	4

- * Inductance tested at 150MHz.
- * Inductance tolerance : K=+/-10% ; J=+/-5%..
- * Operating temperature range : -40°C to +125°C