



# SRIDB5050 SERIES ~ SMD Common Mode Choke



RoHS Compliant

## PART NUMBERING SYSTEM

<b>SRIDB</b>	<b>5050</b>	—	<b>900R</b>	—	<b>LF</b>
TYPE	DIMENSIONS		IMPEDANCE		LEAD FREE

## SHAPES AND DIMENSIONS

UNIT : mm

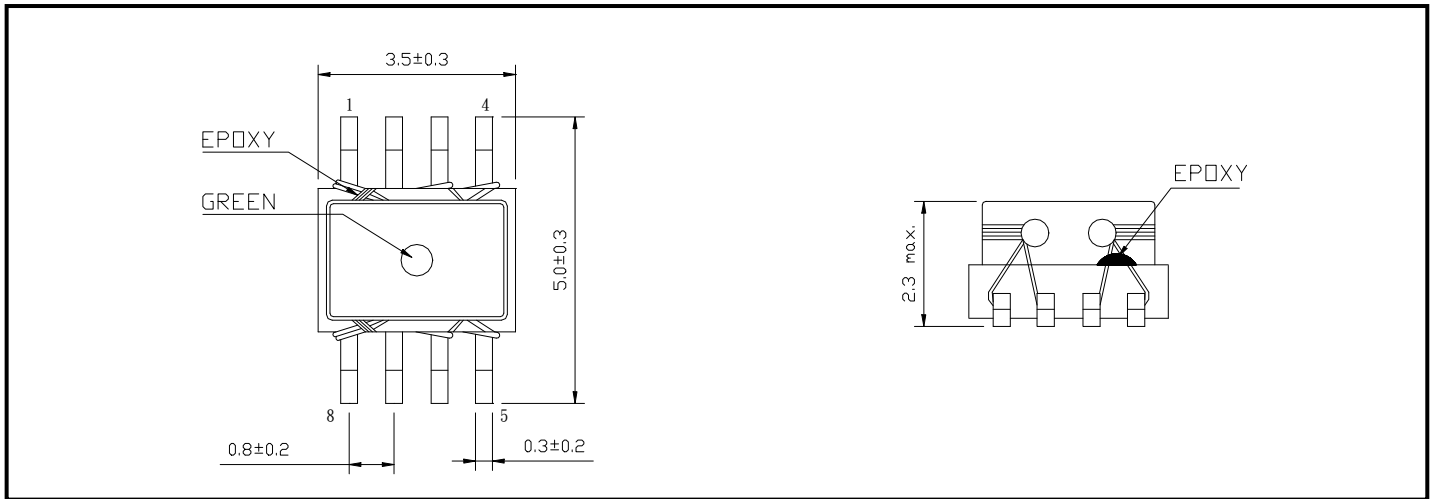

## SPECIFICATION TABLE

PART NUMBER	RATED CURRENT (mA)	COMMON MODE IMPEDANCE (Ω)		DCR (Ω) max.	WITHSTANDING VOLTAGE (Vdc)	INSULATION RESISTANCE (Ω) (min)	OPERATING TEMP. ( °C )
		100MHz	300MHz				
SRIDB5050-900R-LF	500	90±25%	250 (TYP.)	0.10	100	100 M	-40~+85
SRIDB5050-201R-LF	500	200±25%	300 (TYP.)	0.12	100	100 M	-40~+85
SRIDB5050-301R-LF	500	300±25%	530 (TYP.)	0.15	100	100 M	-40~+85
SRIDB6560-501R-LF	500	500±25%	900 (TYP.)	0.16	100	100 M	-40~+85

TEST EQUIPMENT : HP-4291A



# SRIDB5050 SERIES ~ SMD Common Mode Choke



RoHS Compliant

## PACKAGING SPECIFICATION

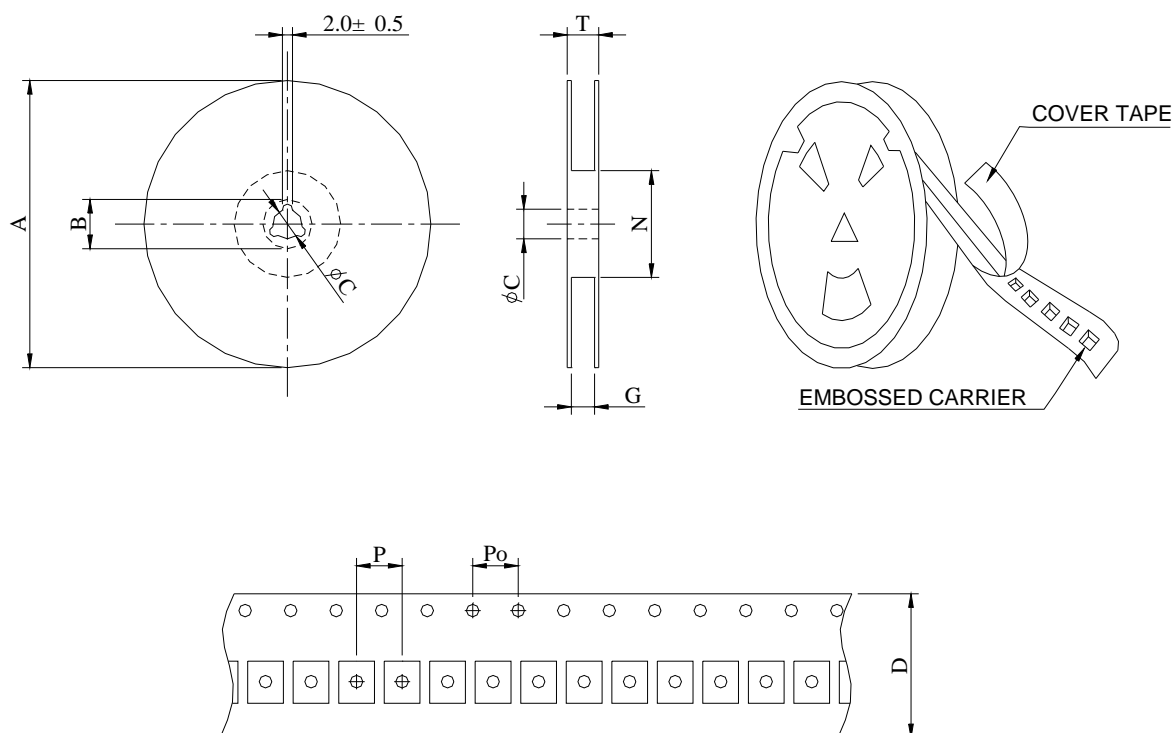

SERIES	STAYLE	Q' TY (PCS)	DIMENSIONS (m/m)								
			A	B±0.8	C±0.5	D	G <sup>+0</sup>	N <sup>0</sup>	P	Po	T
SRIDB5050R	12	3000	330	21	13	12	12.4	75	8	4	16.4



# SRIDB5050 SERIES ~ SMD Common Mode Choke



RECOMMENDED PC BOARD PATTERN (unit:mm)

RoHS Compliant

SRIDB 5050 R

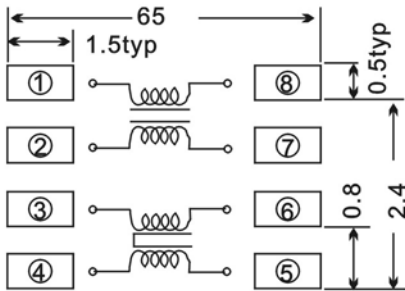

## RECOMMENDED REFLOW SOLDERING CONDITIONS

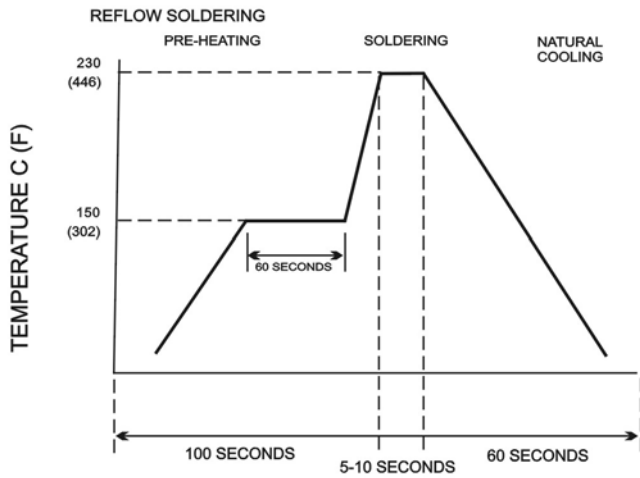

## MEASURING CIRCUIT

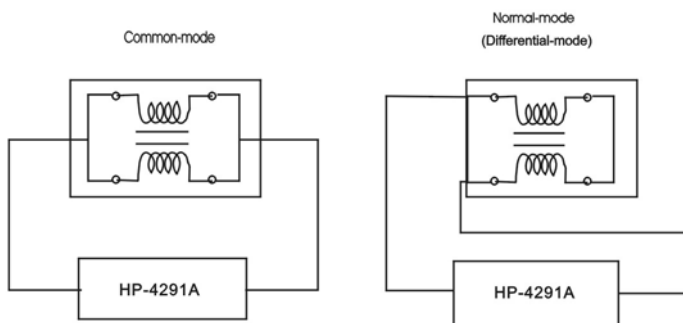



**Coilmaster Electronics Co., Ltd.**

9F-3 No.398, Huan Bei Rd. Chung Li City, Taoyuan 320, Taiwan

Tel : +886-3-422-8279

Fax : +886-3-422-8734

E-mail : [info@coilmaster.com.tw](mailto:info@coilmaster.com.tw)

Web Site : [www.coilmaster.com.tw](http://www.coilmaster.com.tw)

# SRIDB5050 SERIES ~ SMD Common Mode Choke



RoHS Compliant

## TYPICAL ELECTRICAL CHARACTERISTICS

SRIDB 5050R SERIES COMMON MODE vs. NORMAL MODE CHARACTERISTICS

