



Coilmaster Electronics Co., Ltd.
9F-3 No.398, Huan Bei Rd. Chung Li City, Taoyuan 320, Taiwan

Email: sales@bec.co.uk
Web: www.bec.co.uk



SEP2510EB SERIES~ High Current SMD Power Inductors



PART NUMBERING SYSTEM

SEP	2510EB	—	1R0M	—	LF
TYPE	DIMENSIONS		INDUCTANCE		LEAD FREE

FEATURES :

- Magnetically Molding High Current Power Inductors .
- Low profile (1.0mm max. height) and 2.5 mm (Length) * 2.0mm (Width) compact original design .
- Low DC resistance and Suitable for large current .
- Low acoustic noise and low leakage flux noise by shielded construction .
- Ideal for DC – DC converter inductor application in hand help personal Computer ,etc .
- Halogen Free , 100% lead (Pb) Free and RoHS compliant .

SHAPES AND DIMENSIONS :

UNIT : mm

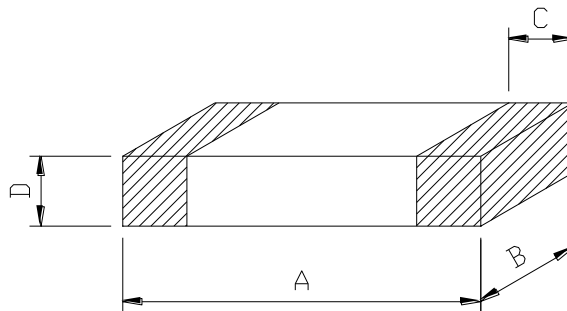

A=2.50±0.3 B=2.00±0.3 C=0.60±0.3 D=1.00Max.

RECOMMENDED PATTERNS

UNIT : mm

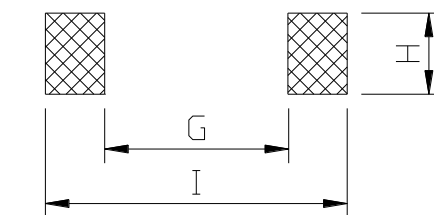

H=2.0 G= 1.2 I = 2.8



SEP2510EB SERIES~ High Current SMD Power Inductors



SPECIFICATION TABLE

PART NUMBER	INDUCTANCE (μ H)	Isat (A) (Max.)	Irms (A) (Max.)	DCR (m Ω) (Typ.)	DCR (m Ω) (Max.)
SEP2510EB-R24M-LF	0.24 \pm 20%	8.00	5.50	13.0	18.0
SEP2510EB-R33M-LF	0.33 \pm 20%	6.50	4.80	18.0	24.0
SEP2510EB-R47M-LF	0.47 \pm 20%	5.50	4.20	21.0	27.0
SEP2510EB-R68M-LF	0.68 \pm 20%	4.50	3.70	32.0	40.0
SEP2510EB-1R0M-LF	1.0 \pm 20%	4.70	4.00	39.0	46.0
SEP2510EB-1R5M-LF	1.5 \pm 20%	3.10	2.40	68.0	75.0
SEP2510EB-2R2M-LF	2.2 \pm 20%	2.50	2.20	87.0	97.0

- Isat : DC current at which the inductance drops 30% (Max.) from its value without current.
- I rms : Average current for a 40°C temperature rise above 25°C ambient.
- Test Frequency at 2MHz / 0.2V
- Operating temperature range -40°C to +125°C , Electrical specifications at 25°C.

PACKAGING SPECIFICATION

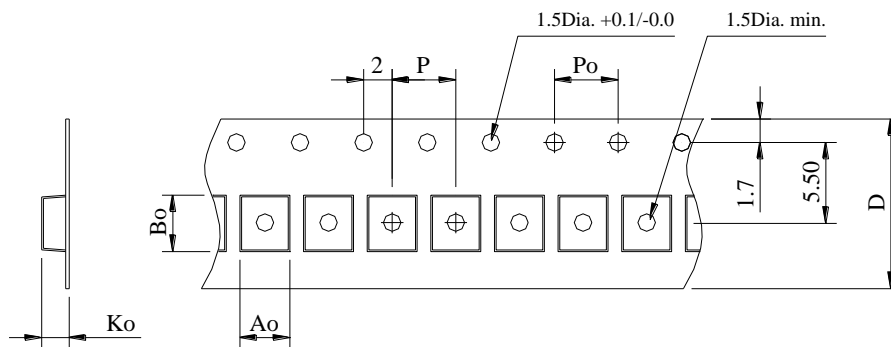

STAYLE	Q' TY (PCS)	DIMENSIONS (m/m)					
		Ao	Bo	Ko	P	Po	D
7"	3,000	2.5 \pm 0.1	2.8 \pm 0.1	1.15 \pm 0.1	4.0 \pm 0.1	4.0 \pm 0.1	8 \pm 0.2